

# SureStep™ Stepping Systems

## User Manual

Manual #: **STP-SYS-M-W0**  
2nd Ed, Rev C

**STP-DRV-xxxx**  
Microstepping Drives



**STP-PWR-xxxx**  
Stepping System  
Power Supplies



**STP-MTR(H)-xxxx**  
Connectorized Bipolar Stepping Motors



**STP-EXT(H)-020**  
Step Motor Extension Cable

BLANK  
PAGE

# ⚡ WARNING ⚡

Thank you for purchasing automation equipment from Automationdirect.com®, doing business as AutomationDirect. We want your new automation equipment to operate safely. Anyone who installs or uses this equipment should read this publication (and any other relevant publications) before installing or operating the equipment.

To minimize the risk of potential safety problems, you should follow all applicable local and national codes that regulate the installation and operation of your equipment. These codes vary from area to area and usually change with time. It is your responsibility to determine which codes should be followed, and to verify that the equipment, installation, and operation is in compliance with the latest revision of these codes.

At a minimum, you should follow all applicable sections of the National Fire Code, National Electrical Code, and the codes of the National Electrical Manufacturer's Association (NEMA). There may be local regulatory or government offices that can also help determine which codes and standards are necessary for safe installation and operation.

Equipment damage or serious injury to personnel can result from the failure to follow all applicable codes and standards. We do not guarantee the products described in this publication are suitable for your particular application, nor do we assume any responsibility for your product design, installation, or operation.

Our products are not fault-tolerant and are not designed, manufactured or intended for use or resale as on-line control equipment in hazardous environments requiring fail-safe performance, such as in the operation of nuclear facilities, aircraft navigation or communication systems, air traffic control, direct life support machines, or weapons systems, in which the failure of the product could lead directly to death, personal injury, or severe physical or environmental damage ("High Risk Activities"). AutomationDirect specifically disclaims any expressed or implied warranty of fitness for High Risk Activities.

For additional warranty and safety information, see the Terms and Conditions section of our catalog. If you have any questions concerning the installation or operation of this equipment, or if you need additional information, please call us at 770-844-4200.

This publication is based on information that was available at the time it was printed. At AutomationDirect we constantly strive to improve our products and services, so we reserve the right to make changes to the products and/or publications at any time without notice and without any obligation. This publication may also discuss features that may not be available in certain revisions of the product.

## Trademarks

This publication may contain references to products produced and/or offered by other companies. The product and company names may be trademarked and are the sole property of their respective owners. AutomationDirect disclaims any proprietary interest in the marks and names of others.

**Copyright 2004, 2007, 2008, 2009, 2011 – Automationdirect.com® Incorporated  
All Rights Reserved**

No part of this manual shall be copied, reproduced, or transmitted in any way without the prior, written consent of Automationdirect.com® Incorporated. AutomationDirect retains the exclusive rights to all information included in this document.

# ⚡ AVERTISSEMENT ⚡

Nous vous remercions d'avoir acheté l'équipement d'automatisation de Automationdirect.com®, en faisant des affaires comme AutomationDirect. Nous tenons à ce que votre nouvel équipement d'automatisation fonctionne en toute sécurité. Toute personne qui installe ou utilise cet équipement doit lire la présente publication (et toutes les autres publications pertinentes) avant de l'installer ou de l'utiliser.

Afin de réduire au minimum le risque d'éventuels problèmes de sécurité, vous devez respecter tous les codes locaux et nationaux applicables régissant l'installation et le fonctionnement de votre équipement. Ces codes diffèrent d'une région à l'autre et, habituellement, évoluent au fil du temps. Il vous incombe de déterminer les codes à respecter et de vous assurer que l'équipement, l'installation et le fonctionnement sont conformes aux exigences de la version la plus récente de ces codes.

Vous devez, à tout le moins, respecter toutes les sections applicables du Code national de prévention des incendies, du Code national de l'électricité et des codes de la National Electrical Manufacturer's Association (NEMA). Des organismes de réglementation ou des services gouvernementaux locaux peuvent également vous aider à déterminer les codes ainsi que les normes à respecter pour assurer une installation et un fonctionnement sûrs.

L'omission de respecter la totalité des codes et des normes applicables peut entraîner des dommages à l'équipement ou causer de graves blessures au personnel. Nous ne garantissons pas que les produits décrits dans cette publication conviennent à votre application particulière et nous n'assumons aucune responsabilité à l'égard de la conception, de l'installation ou du fonctionnement de votre produit.

Nos produits ne sont pas insensibles aux défaillances et ne sont ni conçus ni fabriqués pour l'utilisation ou la revente en tant qu'équipement de commande en ligne dans des environnements dangereux nécessitant une sécurité absolue, par exemple, l'exploitation d'installations nucléaires, les systèmes de navigation aérienne ou de communication, le contrôle de la circulation aérienne, les équipements de survie ou les systèmes d'armes, pour lesquels la défaillance du produit peut provoquer la mort, des blessures corporelles ou de graves dommages matériels ou environnementaux («activités à risque élevé»). La société AutomationDirect nie toute garantie expresse ou implicite d'aptitude à l'emploi en ce qui a trait aux activités à risque élevé.

Pour des renseignements additionnels touchant la garantie et la sécurité, veuillez consulter la section Modalités et conditions de notre documentation. Si vous avez des questions au sujet de l'installation ou du fonctionnement de cet équipement, ou encore si vous avez besoin de renseignements supplémentaires, n'hésitez pas à nous téléphoner au 770-844-4200.

Cette publication s'appuie sur l'information qui était disponible au moment de l'impression. À la société AutomationDirect, nous nous efforçons constamment d'améliorer nos produits et services. C'est pourquoi nous nous réservons le droit d'apporter des modifications aux produits ou aux publications en tout temps, sans préavis ni quelque obligation que ce soit. La présente publication peut aussi porter sur des caractéristiques susceptibles de ne pas être offertes dans certaines versions révisées du produit.

## Marques de commerce

La présente publication peut contenir des références à des produits fabriqués ou offerts par d'autres entreprises. Les désignations des produits et des entreprises peuvent être des marques de commerce et appartiennent exclusivement à leurs propriétaires respectifs. AutomationDirect nie tout intérêt dans les autres marques et désignations.

**Copyright 2004, 2007, 2008, 2009, 2011 – Automationdirect.com® Incorporated  
Tous droits réservés**

Nulle partie de ce manuel ne doit être copiée, reproduite ou transmise de quelque façon que ce soit sans le consentement préalable écrit de la société Automationdirect.com® Incorporated.

AutomationDirect conserve les droits exclusifs à l'égard de tous les renseignements contenus dans le présent document.

# ⚡ WARNING ⚡



---

WARNING: Read this manual thoroughly before using *SureStep*<sup>™</sup> Stepping System drives, motors, and power supplies.

---



---

WARNING: AC input power must be disconnected before performing any maintenance. Do not connect or disconnect wires or connectors while power is applied to the circuit. Maintenance must be performed only by a qualified technician.

---



---

WARNING: There are highly sensitive MOS components on the printed circuit boards, and these components are highly sensitive to static electricity. To avoid damage to these components, do not touch the components or the circuit boards with metal objects or with your bare hands.

---



---

WARNING: Ground the *SureStep*<sup>™</sup> power supply using the ground terminal. The grounding method must comply with the laws of the country where the equipment is to be installed. Refer to “Power Supply Terminal & Component Layout” in the Power Supply chapter.

---

BLANK  
PAGE

# SURESTEP™

## Stepping Systems

### USER MANUAL

Please include the Manual Number and the Manual Issue, both shown below, when communicating with Technical Support regarding this publication.

**Manual Number:**        **STP-SYS-M-WO**

**Issue:**                    **Second Edition, Revision C**

**Issue Date:**            **02/2011**

Publication History		
Issue	Date	Description of Changes
First Edition	7/28/04	Original
1st Ed, Rev A	8/26/04	AC power fuse changed from 2A slow blow to 3A fast acting, plus other minor changes and corrections.
1st Ed, Rev B	3/28/07	Added wiring diagrams for both sink and source for indexers and PLCs with 12-24 VDC outputs. Also corrected value for $r^4$ from 64 to 1296 in formula under Step 4 on page 15 of Appendix A.
Second Edition	11/2008	Changed name of user manual (was STP-SYS-M). Added new components: 3 new power supplies: STP-PWR-4805, -4810, -7005 2 new drives: STP-DRV-4850, -80100 5 new motors: STP-MTR-17040, STP-MTRH-23079, -34066, -34097, -34127 2 new cables: STP-EXTH-020, STP-232RJ11-CBL Other minor changes throughout.
2nd Ed, Rev A	06/2009	Advanced drives RS-232 communication port pin-out; pages 3-4 & B-7
2nd Ed, Rev B	09/2009	Advanced drives Digital Output max current rating; page 3-10
2nd Ed, Rev C	02/2011	Ch 2,3: drive storage temperature specs Ch 4: motor storage temperature specs; motor Torque vs Speed curves Ch 5: power supply Watt loss specs

BLANK  
PAGE



# TABLE OF CONTENTS

---



Chapter 1: Getting Started . . . . .	1-1
Manual Overview . . . . .	1-2
<i>SureStep</i> <sup>™</sup> System Introduction . . . . .	1-3
Microstepping Drives Introduction . . . . .	1-4
Bipolar Step Motor Introduction . . . . .	1-6
Stepping System Power Supply Introduction . . . . .	1-7
Selecting the Stepping System . . . . .	1-8
Use with <i>Direct</i> LOGIC PLCs . . . . .	1-8
Chapter 2: <i>SureStep</i> <sup>™</sup> STP-DRV-4035 Microstepping Drive . . . . .	2-1
Features . . . . .	2-2
Block Diagram . . . . .	2-2
Specifications . . . . .	2-3
Typical Wiring Diagram . . . . .	2-4
Connection and Adjustment Locations . . . . .	2-4
The Enable Input . . . . .	2-9
Setting Phase Current . . . . .	2-10
Microstepping . . . . .	2-12
Idle Current Reduction . . . . .	2-13
Self Test . . . . .	2-13
Choosing a Power Supply . . . . .	2-14
Mounting the Drive . . . . .	2-15
Dimensions . . . . .	2-16

Chapter 3: *SureStep*<sup>™</sup> Advanced Microstepping Drives . . .3-1

- Features . . . . .3-2
- Specifications . . . . .3-3
- Typical Wiring Diagram . . . . .3-4
- Connection Locations & Pin-out . . . . .3-4
- Connecting the Motor . . . . .3-5
- Connecting the Power Supply . . . . .3-6
- Connecting the I/O . . . . .3-7
- Drive Configuration . . . . .3-11
- SureStep* Pro Software . . . . .3-13
- Choosing a Power Supply . . . . .3-16
- Mounting the Drive . . . . .3-17
- Dimensions and Mounting Slot Locations . . . . .3-17

Chapter 4: *SureStep*<sup>™</sup> Stepping Motors . . . . .4-1

- Features . . . . .4-2
- Design and Installation Tips . . . . .4-2
- Specifications . . . . .4-3
- Power Supply and Step Motor Drive . . . . .4-4
- Mounting the Motor . . . . .4-4
- Connecting the Motor . . . . .4-4
- Motor Dimensions and Cabling . . . . .4-5
- Torque vs. Speed Charts . . . . .4-7

Chapter 5: *SureStep*<sup>™</sup> Stepping System Power Supplies .5-1

- Features . . . . .5-2
- Specifications . . . . .5-3
- Power Supply Terminal & Component Layout . . . . .5-4
- Mounting the Power Supply . . . . .5-5
- Dimensions . . . . .5-6

---

Appendix A: Selecting the <i>SureStep</i> <sup>™</sup> Stepping System . . .	A-1
Selecting the <i>SureStep</i> <sup>™</sup> Stepping System . . . . .	A-2
Leadscrew - Example Calculations . . . . .	A-8
Belt Drive - Example Calculations . . . . .	A-11
Index Table - Example Calculations . . . . .	A-14
Engineering Unit Conversion Tables, Formulae, & Definitions: . . . . .	A-17
 Appendix B: Using <i>SureStep</i> <sup>™</sup> with <i>Direct</i> LOGIC PLCs . . .	B-1
Compatible <i>Direct</i> LOGIC PLCs and Modules . . . . .	B-2
Typical Connections to a DL05 PLC . . . . .	B-4
Typical Connections to an H0-CTRIO . . . . .	B-5
Typical Connections – Multiple Drive/Motors . . . . .	B-6
Typical PLC Serial Connections to an Advanced <i>SureStep</i> Drive . . . . .	B-7

BLANK  
PAGE

# GETTING STARTED

---



## In This Chapter...

Manual Overview . . . . .	1-2
Overview of this Publication . . . . .	1-2
Who Should Read this Manual . . . . .	1-2
Technical Support . . . . .	1-2
Special Symbols . . . . .	1-2
<i>SureStep</i> <sup>™</sup> System Introduction . . . . .	1-3
<i>SureStep</i> <sup>™</sup> System Recommended Component Compatibility . . . . .	1-3
<i>SureStep</i> <sup>™</sup> Part Number Explanation . . . . .	1-3
Microstepping Drives Introduction . . . . .	1-4
Standard Microstepping Drive . . . . .	1-4
Advanced Microstepping Drive . . . . .	1-5
Bipolar Step Motor Introduction . . . . .	1-6
Stepping System Power Supply Introduction . . . . .	1-7
Selecting the Stepping System . . . . .	1-8
Use with <i>Direct</i> LOGIC PLCs . . . . .	1-8

## Manual Overview

### Overview of this Publication

Thank you for selecting the *SureStep*™ Stepping System components. This user manual describes the selection, installation, configuration, and methods of operation of the *SureStep*™ Stepping System. We hope our dedication to performance, quality and economy will make your motion control project successful.

### Who Should Read this Manual

This manual contains important information for those who will install, maintain, and/or operate any of the *SureStep*™ Stepping System devices.

### Technical Support

By Telephone: 770-844-4200  
(Mon.-Fri., 9:00 am – 6:00 pm E.T.)

On the Web: [www.automationdirect.com](http://www.automationdirect.com)

Our technical support group is glad to work with you in answering your questions. If you cannot find the solution to your particular application, or, if for any reason you need additional technical assistance, please call technical support at 770-844-4200. We are available weekdays from 9:00 am to 6:00 pm Eastern Time.

We also encourage you to visit our web site where you can find technical and non-technical information about our products and our company. Visit us at [www.automationdirect.com](http://www.automationdirect.com).

### Special Symbols



---

*When you see the “notepad” icon in the left-hand margin, the paragraph to its immediate right will be a special note which presents information that may make your work quicker or more efficient.*

---



---

**When you see the “exclamation mark” icon in the left-hand margin, the paragraph to its immediate right will be a WARNING. This information could prevent injury, loss of property, or even death (in extreme cases).**

---

## SureStep™ System Introduction

SureStep open-loop stepping systems provide simple and accurate control of position and speed where lower power and cost are considerations. The SureStep family of stepping components includes power supplies, drives, motors, and cables. The **Direct**LOGIC family of PLCs or other indexers and motion controllers can be used to provide the signals that are "translated" by the microstepping drives into precise movement of the stepping motor shaft.

### SureStep™ System Recommended Component Compatibility

SureStep™ System Recommended Component Compatibility				
Drives (1)	Power Supplies (1)		Motors & Extension Cables (2,3)	
STP-DRV-4035	-	-	STP-PWR-3204	STP-MTR-xxxxx & STP-EXT-020 STP-MTRH-xxxxx & STP-EXTH-020
STP-DRV-4850	-	STP-PWR-4805		
STP-DRV-80100	STP-PWR-7005	STP-PWR-4810		
<p>1) <b>Caution:</b> Do not use a power supply that exceeds the drive input voltage range. Using a lower voltage power supply with a higher voltage drive is acceptable, but will not provide full system performance.</p> <p>2) MTR motors have connectors compatible with the EXT extension cables.</p> <p>3) MTRH motors have connectors compatible with the EXTH extension cables.</p>				

### SureStep™ Part Number Explanation

STP- MTR H - 23079

#### Component Capacity

For DRV: 2-digit max nominal voltage followed by max current with 1 implied decimal place  
4035: 40V, 3.5A  
4850: 48V, 5.0A  
80100: 80V, 10.0A

For EXT(H): cable length in feet

For MTR(H): 2-digit NEMA frame size followed by approximate length in mm

For PWR: 2-digit output voltage followed by output current

#### Component Type

DRV: stepper drive  
EXT: motor extension cable  
EXTH: high-power motor extension cable  
MTR: stepper motor  
MTRH: high-power stepper motor  
PWR: power supply

#### SureStep Series Designation: STP

# Microstepping Drives Introduction

There are two different basic types of microstepping drives offered in the *SureStep*™ series. One DIP-switch configurable model with a pulse input is available, as well as two software configurable advanced models with multiple operating modes.

## Standard Microstepping Drive

The *SureStep*™ STP-DRV-4035 standard microstepping drive uses pulse input signals, and is configured with DIP switches on the drive. To use this drive in a step motor control system, you will need the following:

- 12-42 volt DC power supply for the motor drive. The *SureStep* STP-PWR-3204 power supply from AutomationDirect is the best choice. If you decide not to use the STP-PWR-3204, please read the section entitled “Choosing a Power Supply” in the STP-DRV-4035 Drive chapter of this user manual.
- A source of step pulses. Signal may be sinking (NPN), sourcing (PNP), or differential.
- The step inputs can be CW/CCW, step and direction, or quadrature.
- A compatible step motor, such as an AutomationDirect *SureStep* STP-MTR(H)-xxxxx. (Motor extension cables STP-EXT(H)-020 are also available.)
- A small flat blade screwdriver for tightening the connectors.

The STP-DRV-4035 standard microstepping drive is an open frame design.



STP-DRV-4035

Refer to the “*SureStep* STP-DRV-4035 Microstepping Drive” chapter of this user manual for complete details on the installation, configuration, and wiring of this drive.



## Advanced Microstepping Drive

The *SureStep*™ advanced microstepping drives (STP-DRV-4850 & -80100) are capable of accepting several different forms of input signals for control: pulse, analog, serial communication, or internal indexing. These drives are configured by computer with software which is included with the drive. To use one of these drives in a step motor control system, you will need the following:

- A DC power supply for the motor drive. A compatible *SureStep* STP-PWR-xxxx power supply from AutomationDirect is the best choice.
- A source of input control signals, such as a **Direct**Logic PLC from AutomationDirect.
- A compatible step motor, such as an AutomationDirect *SureStep* STP-MTR(H)-xxxxx. (Motor extension cables STP-EXT(H)-020 are also available.)
- A small flat blade screwdriver for tightening the connectors.

The *SureStep* advanced microstepping drives are enclosed with removable wiring terminal blocks.



STP-DRV-80100

Refer to the “*SureStep*™ Advanced Microstepping Drives” chapter of this user manual for complete details on the installation, configuration, and wiring of this drive.

## Bipolar Step Motor Introduction

AutomationDirect offers nine different models of bipolar step motors with mounting flanges in NEMA frame sizes 17, 23, and 34. There are five High Torque (STP-MTR-xxxxx) motors available, as well as four Higher Torque (STP-MTRH-xxxxx) motors. All of the motors have a 12 inch connectorized pigtail cable, and optional matching 20 ft connectorized extension cables (STP-EXT(H)-020) are also available.

Refer to the “*SureStep™* Stepping Motors” chapter in this user manual for complete details on the specifications, installation, mounting, dimensions, and wiring of the *SureStep* step motors.



**STP-MTR(H)-xxxxx  
NEMA 17, 23, 34  
Frame Sizes**

## Stepping System Power Supply Introduction

The *SureStep* stepping system power supplies are designed to work with *SureStep* microstepping drives and motors. The different power supply models can provide unregulated DC power at the applicable voltage and current levels for various *SureStep* drives and motors. The power supplies also provide a regulated 5VDC, 500 mA logic supply output for indexer and PLC logic outputs to control the *SureStep* drives.



The stepping system power supplies can supply power for multiple *SureStep* STP-DRV-xxxx microstepping motor drives, depending on step motor size and application requirements.

Refer to the Power Supply chapter of this user manual for complete details on the specifications, installation, mounting, dimensions, and wiring of the *SureStep* stepping system power supplies.

## Selecting the Stepping System

Refer to Appendix A: Selecting the *SureStep*™ Stepping System for detailed information on how to calculate requirements for various applications using stepping motors for motion control.

## Use with *Direct*LOGIC PLCs

Refer to Appendix B: Using *SureStep*™ with *Direct*LOGIC PLCs for detailed information on wiring the *SureStep* Stepping System components to *Direct*LOGIC PLCs and high-speed counter modules.

The following is a summary of the *Direct*LOGIC PLCs<sup>(1)</sup> and module part numbers that are suitable to work with the *SureStep* Stepping Systems:

D0-05AD

D0-05DD

D0-05DD-D

D0-06DD1

D0-06DD2

D0-06DD1-D

D0-06DD2-D

H0-CTRIO

F1-130AD

F1-130DD

F1-130DD-D

H2-CTRIO<sup>(2)</sup>

D2-CTRINT

T1H-CTRIO<sup>(2)</sup>

H4-CTRIO

(1) Any *Direct*LOGIC PLC capable of RS-232 ASCII communication can write serial commands to the *SureStep Advanced* Microstepping Drives (STP-DRV-4850 & -80100). These PLCs include DL 05, 06, 250-1, 260, 350, & 450. However, we strongly recommend using DL06 or DL260 PLCs for serial commands due to their more advanced ASCII instruction set which includes PRINTV and VPRINT commands.

(2) The H2-CTRIO and T1H-CTRIO High Speed Counter I/O Interface Modules can also be used to control the *SureStep* Stepping System in PC-Based Control systems with Think & Do/Studio, or with our embedded WinPLC/EBC module plugged into the CPU slot of the DL205 base.

**SURESTEP™**  
**STP-DRV-4035**  
**MICROSTEPPING DRIVE**

---



**In This Chapter...**

Features . . . . .	2-2
Block Diagram . . . . .	2-2
Specifications . . . . .	2-3
Typical Wiring Diagram . . . . .	2-4
Connection and Adjustment Locations . . . . .	2-4
Connecting the Motor . . . . .	2-5
Connecting the Power Supply . . . . .	2-6
Connecting the Logic . . . . .	2-7
Using Logic That is Not 5 volt TTL Level . . . . .	2-9
The Enable Input . . . . .	2-9
Setting Phase Current . . . . .	2-10
Current Setting Formula . . . . .	2-10
Current Setting Table . . . . .	2-11
Microstepping . . . . .	2-12
Idle Current Reduction . . . . .	2-13
Self Test . . . . .	2-13
Choosing a Power Supply . . . . .	2-14
Mounting the Drive . . . . .	2-15
Dimensions . . . . .	2-16

## Features

- Drives sizes 17 through 34 step motors
- Pulse width modulation, MOSFET 3 state switching amplifiers
- Phase current from 0.4 to 3.5 amps (switch selectable, 32 settings)
- Optically isolated step, direction and enable inputs
- Half, 1/5, 1/10, 1/50 step (switch selectable)
- Automatic 50% idle current reduction (can be switched off)



## Block Diagram

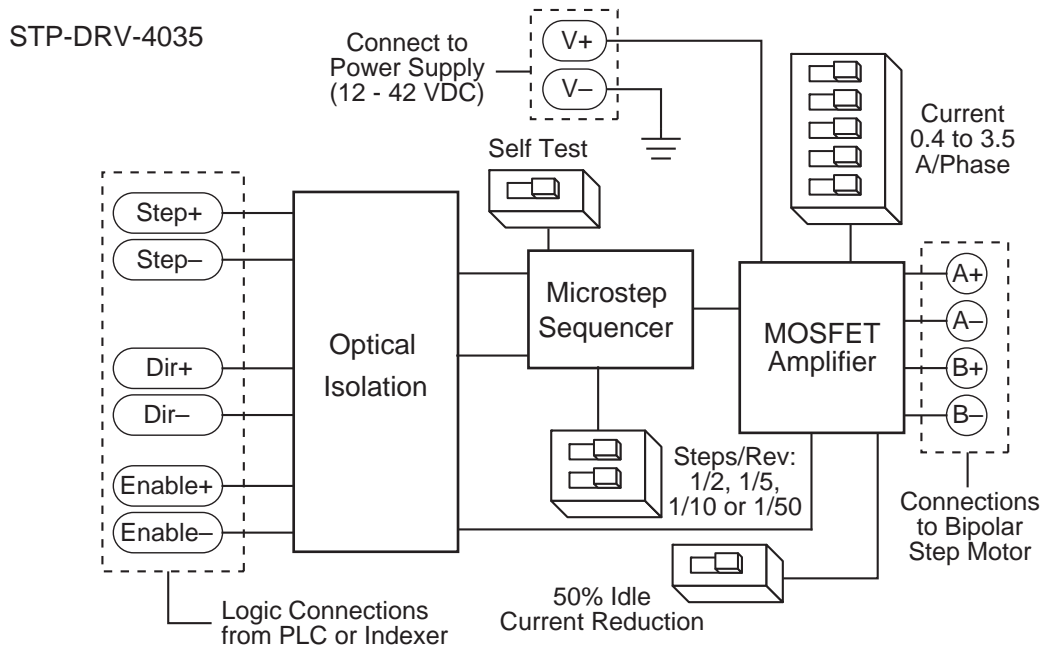

## Specifications

SureStep™ Microstepping Drives Specifications		
Part Number	STP-DRV-4035	
Input Power (with red Power On LED)	12-42 VDC (including ripple voltage)	
Output Power	Output current selectable from 0.4 to 3.5 Amps/phase motor current (maximum output power is 140 W)	
Current Controller	Dual H-bridge Bipolar Chopper (3-state 20 kHz PWM with MOSFET switches)	
Input Signals	Input Signal Circuit	Opto-coupler input with 440 Ohm resistance (5 to 15 mA input current), Logic Low is input pulled to 0.8 VDC or less, Logic High is input 4 VDC or higher
	Pulse Signal	Motor steps on falling edge of pulse and minimum pulse width is 0.5 microseconds
	Direction Signal	Needs to change at least 2 microseconds before a step pulse is sent
	Enable Signal	Logic 1 will disable current to the motor (current is enabled with no hook-up or logic 0)
DIP Switch Selectable Functions	Self Test	Off or On (uses half-step to rotate 1/2 revolution in each direction at 100 steps/second)
	Microstepping	400 (200x2), 1,000 (200x5), 2,000 (200x10), or 10,000 (200x50) steps/rev
	Idle Current Reduction	0% or 50% reduction (idle current setting is active if motor is at rest for 1 second or more)
	Phase Current Setting	0.4 to 3.5 Amps/phase with 32 selectable levels
Drive Cooling Method	Natural convection (mount drive to metal surface if possible)	
Dimensions	3 x 4 x 1.5 inches [76.2 x 101.6 x 38.1 mm]	
Mounting	Use #4 screws to mount on wide side (4 screws) or narrow side (2 screws)	
Connectors	Screw terminal blocks with AWG 18 maximum wire size	
Weight	9.3 oz. [264g]	
Storage Temperature	-20–80 °C [-4–176 °F]	
Chassis Operating Temperature	0–55 °C [32–131 °F] recommended; 70 °C [158 °F] maximum (use fan cooling if necessary); 90% non-condensing maximum humidity	
Agency Approvals	CE (complies with EN55011A and EN50082-1 (1992))	



*Note: The STP-DRV-4035 Microstepping Drive works with 4, 6 and 8 lead bipolar step motors. All **AUTOMATIONDIRECT** SureStep™ motors are four lead bipolar step motors.*

## Typical Wiring Diagram

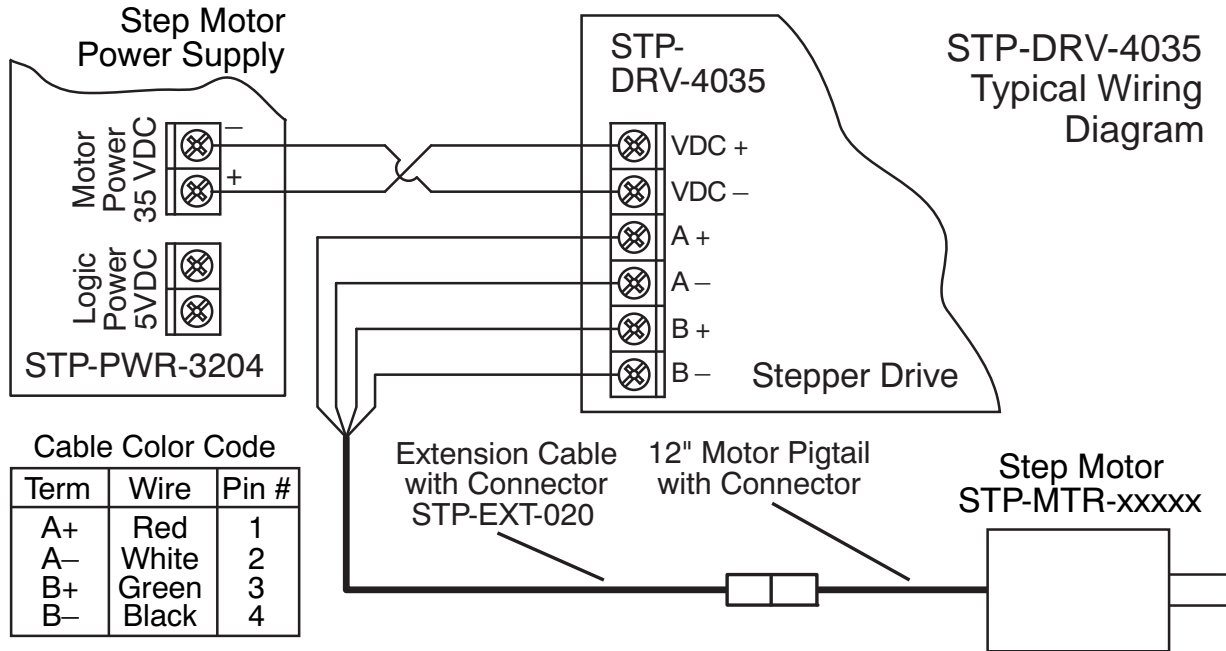

## Connection and Adjustment Locations

The sketch below shows where to find the important connection and adjustment points.

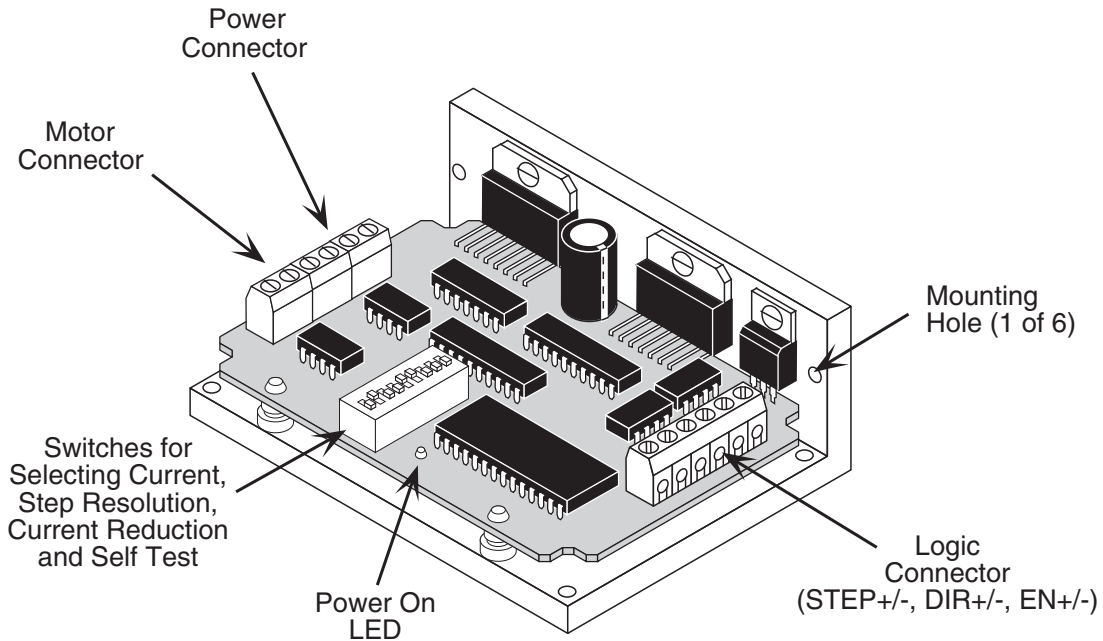



## Connecting the Motor



**WARNING:** When connecting a step motor to the SureStep™ STP-DRV-4035 microstepping drive, be sure that the motor power supply is switched off. When using a motor not supplied by AUTOMATIONDIRECT, secure any unused motor leads so that they can't short out to anything. Never disconnect the motor while the drive is powered up. Never connect motor leads to ground or to a power supply. (See the Typical Wiring Diagram shown on page 2-4 of this chapter for the step motor lead color code of AUTOMATIONDIRECT supplied motors.)

You must now decide how to connect your stepping motor to the SureStep™ STP-DRV-4035 microstepping drive.

### Four lead motors

Four lead motors can only be connected one way. Please follow the wiring diagram shown to the right.

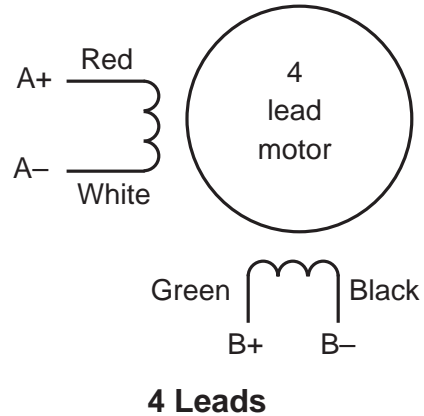

*Note: All AUTOMATIONDIRECT SureStep™ motors are four lead bipolar step motors.*

### Six lead motors

Six lead motors can be connected in series or center tap. In series mode, motors produce more torque at low speeds, but cannot run as fast as in the center tap configuration. In series operation, the motor should be operated at 30% less than rated current to prevent overheating. Wiring diagrams for both connection methods are shown below. **NC** means not connected to anything.

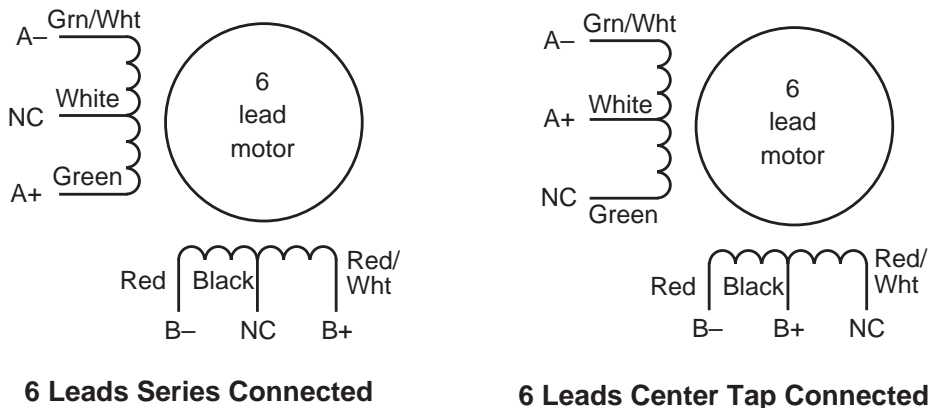

*Note: Be aware that step motor wire lead colors vary from one manufacturer to another.*

### Eight lead motors

Eight lead motors can also be connected in two ways: series or parallel. Series operation gives you more torque at low speeds and less torque at high speeds. When using series connection, the motor should be operated at 30% less than the rated current to prevent over heating. Parallel operation allows a greater torque at high speed. When using parallel connection, the current can be increased by 30% above rated current. Care should be taken in either case to assure the motor is not being overheated. The wiring diagrams for eight lead motors are shown below.

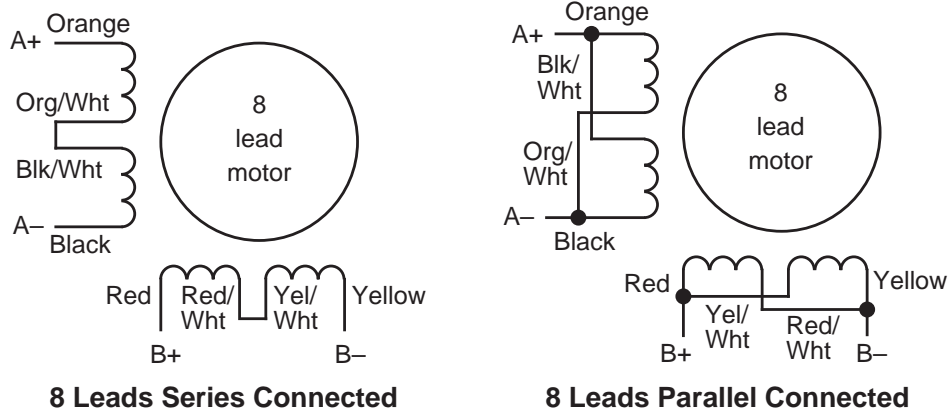

*Note: Be aware that step motor wire lead colors vary from one manufacturer to another.*

### Connecting the Power Supply

The STP-PWR-3204 power supply from **AUTOMATIONDIRECT** is the best choice to power the step motor drive. If you need information about choosing a different power supply, please read the section titled "Choosing a Power Supply" in this manual.

If your power supply does not have a fuse on the output or some kind of short circuit current limiting feature you need to put a 4 amp fast acting fuse between the drive and power supply. Install the fuse on the + power supply lead.

Connect the motor power supply "+" terminal to the driver terminal labeled "+ VDC". Connect power supply "-" to the drive terminal labeled "VDC-". Use no smaller than 18 gauge wire. **Be careful not to reverse the wires.** Reverse connection will destroy your drive and void the warranty.

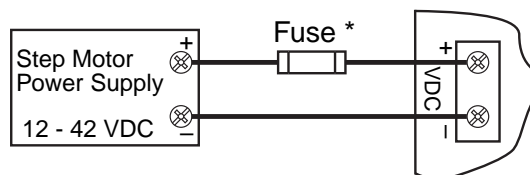

\* External fuse not req'd when using an STP-PWR-3204 P/S; fuse is internal.



**Do NOT use STP-PWR-48xx or -70xx power supplies with an STP-DRV-4035 drive, because those power supplies exceed the voltage limit of this drive.**

## Connecting the Logic

The *SureStep* drive contains optical isolation circuitry to prevent the electrical noise inherent in switching amplifiers from interfering with your circuits. Optical isolation is accomplished by powering the motor driver from a different supply source than your control circuits. There is no electrical connection between the two; signal communication is achieved by infrared light. When your circuit turns on or turns off, an infrared LED (built into the drive), signals a logic state to the phototransistors that are wired to the brains of the drive. A schematic diagram input circuit is shown to the right.

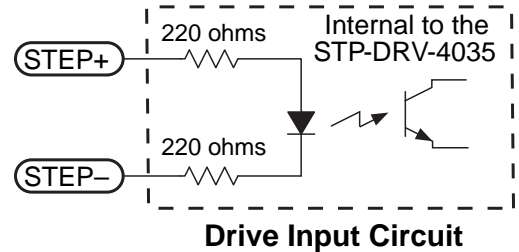

You will need to supply a source of step pulses to the drive at the STEP+ and STEP- terminals and a direction signal at the DIR+ and DIR- terminals, if bidirectional rotation is required. You will also need to determine if the **ENABLE** input terminals will be used in your application. Operation, voltage levels and wiring on the **ENABLE** terminals is the same as the **STEP** and **DIRECTION** terminals. The EN+ and EN- terminal can be left not connected if the enable function is not required.

All logic inputs can be controlled by a DC output signal that is either sinking (NPN), sourcing (PNP), or differential.

On the next couple of pages are examples for connecting various forms of outputs from both indexers and PLCs.

### Connecting to an Indexer with Sinking Outputs

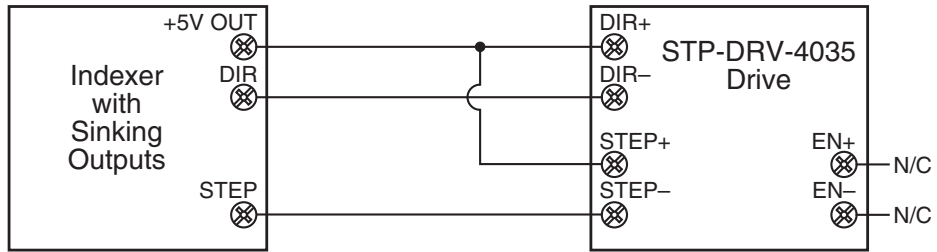

### Connecting to an Indexer with Sourcing Outputs

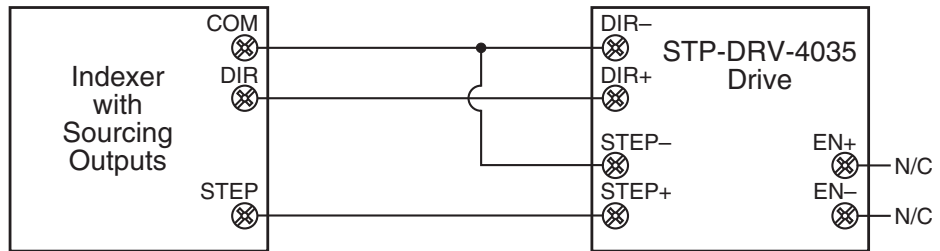

### Connecting to an Indexer with Differential Outputs

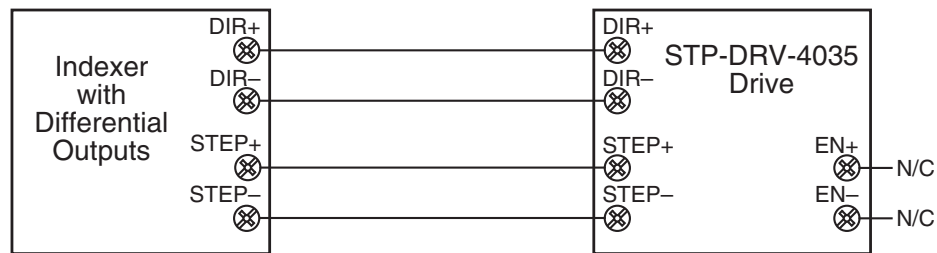

*Note: Many high speed indexers have differential outputs.*

## Using Logic That is Not 5 volt TTL Level

Some step and direction signals, especially those of PLCs, don't use 5 volt logic. You can connect signal levels as high as 24 volts to the *SureStep* drive if you add external dropping resistors to the STEP, DIR and EN inputs, as shown below.

- For 12 volt logic, add 820 ohm, 1/4 watt resistors
- For 24 volt logic, use 2200 ohm, 1/4 watt resistors

### Connecting to an Indexer with Sink or Source 12-24 VDC Outputs

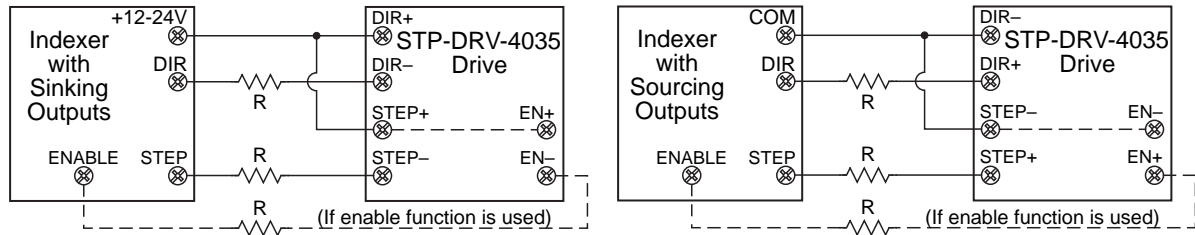

### Connecting to a PLC with Sink or Source 12-24 VDC Outputs

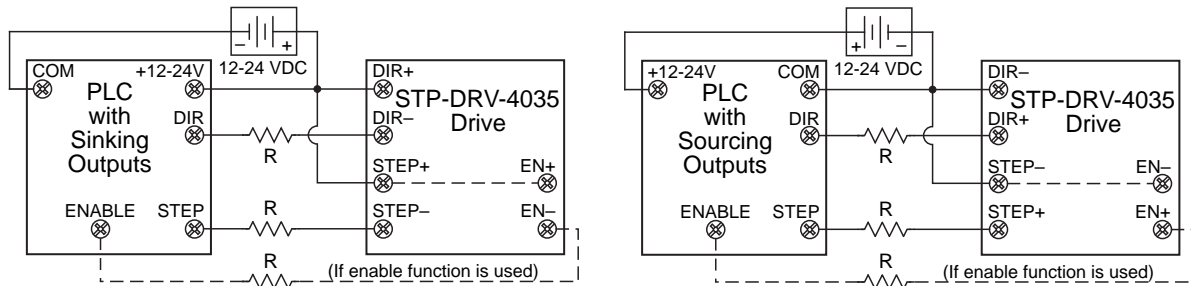

*Note: Most PLCs can use 24 VDC Logic.*

## The Enable Input

The **ENABLE** input allows the user to turn off the current to the motor by providing a positive voltage between EN+ and EN-. The logic circuitry continues to operate, so the drive "remembers" the step position even when the amplifiers are disabled. However, the motor may move slightly when the current is removed depending on the exact motor and load characteristics.



*Note: If you have no need to disable the amplifiers, you don't need to connect anything to the **ENABLE** input.*

**Step Table  
(half stepping)**

Step	A+	A-	B+	B-
0	open	open	+	-
1	+	-	+	-
2	+	-	open	open
3	+	-	-	+
4	open	open	-	+
5	-	+	-	+
6	-	+	open	open
7	-	+	+	-
8	open	open	+	-

DIR=1  
cw  
↓

↑  
DIR=0  
ccw

Step 0 is the Power Up State

## Setting Phase Current

Before you turn on the power supply the first time, you need to set the drive for the proper motor phase current. The rated current is usually printed on the motor label. The SureStep drive current is easy to set. If you wish, you can learn a simple formula for setting current and never need the manual again. Or you can skip to the table on the next page, find the current setting you want, and set the DIP switches according to the picture.

### Current Setting Formula

Locate the bank of tiny switches near the motor connector. Five of the switches, DIP switch positions 5-9, have a value of current printed next to them, such as 0.1, 0.2, 0.4, 0.8 and 1.6. Each switch controls the amount of current, in amperes (A), that its label indicates in addition to the minimum current value of 0.4 Amps. **There is always a base current of 0.4 Amps, even with all five DIP switches set to the "off" position (away from their labels).** To add to that, slide the appropriate switches toward their labels on the PC board. You may need a small screwdriver for this.

**DIP switch current total settings =  
step motor required phase current – 0.4 Amps always present base current**

#### Example





Suppose you want to set the drive for 2.2 Amps per phase based on the step motor showing a phase current of 2.2 Amps. You need the base current of 0.4 Amps plus another 1.6 and 0.2 Amps.

$$2.2 = 0.4 + 1.6 + 0.2$$

Slide the 1.6 and 0.2 Amp DIP switches toward the labels as shown in the figure to the right.

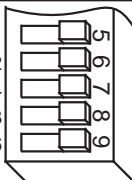
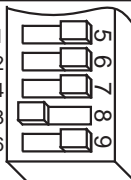
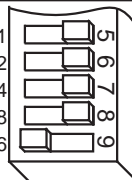
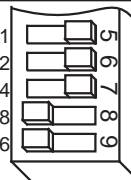
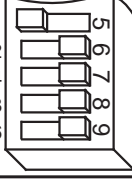
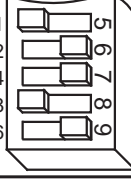
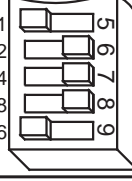
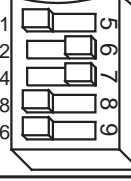
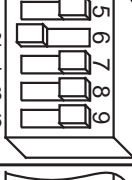
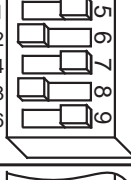
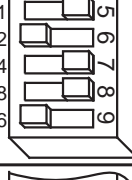
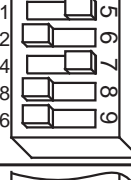
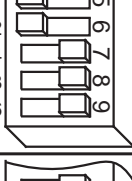
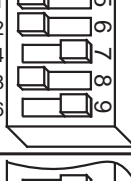
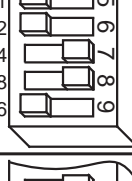
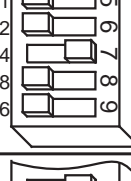
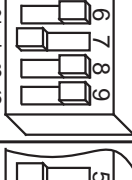
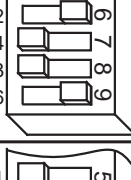
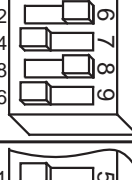
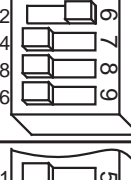

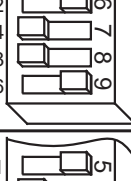
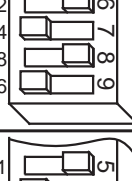
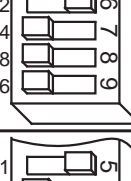
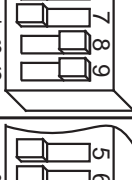
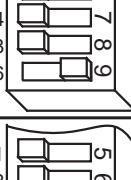
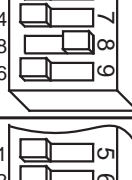
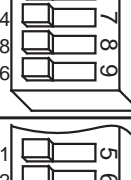
Current Setting Table

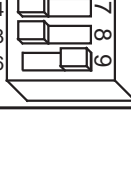
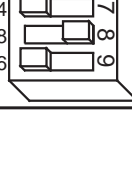
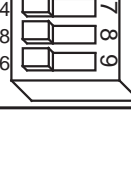
<p><b>0.4</b> 0.1 0.2 AMPS/ 0.4 PHASE 0.8 1.6</p> 	<p><b>1.2</b> 0.1 0.2 AMPS/ 0.4 PHASE 0.8 1.6</p> 	<p><b>2.0</b> 0.1 0.2 AMPS/ 0.4 PHASE 0.8 1.6</p> 	<p><b>2.8</b> 0.1 0.2 AMPS/ 0.4 PHASE 0.8 1.6</p> 	<p>Factory Default</p>
<p><b>0.5</b> 0.1 0.2 AMPS/ 0.4 PHASE 0.8 1.6</p> 	<p><b>1.3</b> 0.1 0.2 AMPS/ 0.4 PHASE 0.8 1.6</p> 	<p><b>2.1</b> 0.1 0.2 AMPS/ 0.4 PHASE 0.8 1.6</p> 	<p><b>2.9</b> 0.1 0.2 AMPS/ 0.4 PHASE 0.8 1.6</p> 	
<p><b>0.6</b> 0.1 0.2 AMPS/ 0.4 PHASE 0.8 1.6</p> 	<p><b>1.4</b> 0.1 0.2 AMPS/ 0.4 PHASE 0.8 1.6</p> 	<p><b>2.2</b> 0.1 0.2 AMPS/ 0.4 PHASE 0.8 1.6</p> 	<p><b>3.0</b> 0.1 0.2 AMPS/ 0.4 PHASE 0.8 1.6</p> 	
<p><b>0.7</b> 0.1 0.2 AMPS/ 0.4 PHASE 0.8 1.6</p> 	<p><b>1.5</b> 0.1 0.2 AMPS/ 0.4 PHASE 0.8 1.6</p> 	<p><b>2.3</b> 0.1 0.2 AMPS/ 0.4 PHASE 0.8 1.6</p> 	<p><b>3.1</b> 0.1 0.2 AMPS/ 0.4 PHASE 0.8 1.6</p> 	
<p><b>0.8</b> 0.1 0.2 AMPS/ 0.4 PHASE 0.8 1.6</p> 	<p><b>1.6</b> 0.1 0.2 AMPS/ 0.4 PHASE 0.8 1.6</p> 	<p><b>2.4</b> 0.1 0.2 AMPS/ 0.4 PHASE 0.8 1.6</p> 	<p><b>3.2</b> 0.1 0.2 AMPS/ 0.4 PHASE 0.8 1.6</p> 	
<p><b>0.9</b> 0.1 0.2 AMPS/ 0.4 PHASE 0.8 1.6</p> 	<p><b>1.7</b> 0.1 0.2 AMPS/ 0.4 PHASE 0.8 1.6</p> 	<p><b>2.5</b> 0.1 0.2 AMPS/ 0.4 PHASE 0.8 1.6</p> 	<p><b>3.3</b> 0.1 0.2 AMPS/ 0.4 PHASE 0.8 1.6</p> 	
<p><b>1.0</b> 0.1 0.2 AMPS/ 0.4 PHASE 0.8 1.6</p> 	<p><b>1.8</b> 0.1 0.2 AMPS/ 0.4 PHASE 0.8 1.6</p> 	<p><b>2.6</b> 0.1 0.2 AMPS/ 0.4 PHASE 0.8 1.6</p> 	<p><b>3.4</b> 0.1 0.2 AMPS/ 0.4 PHASE 0.8 1.6</p> 	
<p><b>1.1</b> 0.1 0.2 AMPS/ 0.4 PHASE 0.8 1.6</p> 	<p><b>1.9</b> 0.1 0.2 AMPS/ 0.4 PHASE 0.8 1.6</p> 	<p><b>2.7</b> 0.1 0.2 AMPS/ 0.4 PHASE 0.8 1.6</p> 	<p><b>3.5</b> 0.1 0.2 AMPS/ 0.4 PHASE 0.8 1.6</p> 	

## Microstepping

Most step motor drives offer a choice between full step and half step resolutions. In most full step drives, both motor phases are used all the time. Half stepping divides each step into two smaller steps by alternating between both phases on and one phase on. Microstepping drives like the *SureStep* drive precisely control the amount of current in each phase at each step position as a means of electronically subdividing the steps even further. The *SureStep* drive offers a choice of half step and three microstep resolutions. The highest setting divides each full step into 50 microsteps, providing 10,000 steps per revolution when using a 1.8° motor.

In addition to providing precise positioning and smooth motion, microstep drives can be used to provide motion in convenient units. When the drive is set to 2,000 steps/rev (1/10 step) and used with a 5 pitch lead screw, you get .0001 inches/step.

Setting the step resolution is easy. Look at the dip switch on the *SureStep* drive. Next to switches 2 and 3, there are labels on the printed circuit board. Each switch has two markings on each end. Switch 2 is marked 1/5, 1/10 at one end and 1/5, 1/50 at the other. Switch 3 is labeled 1/2, 1/5 and 1/10, 1/50. To set the drive for a resolution, push both switches toward the proper label. For example, if you want 1/10 step, push switch 2 toward the 1/10 label (to the left) and push switch 3 toward 1/10 (on the right).

Please refer to the table below and set the switches for the resolution you want.

	<p><b>400</b> STEPS/REV (HALF)</p>	<p><b>2,000</b> STEPS/REV (1/10)</p>
<b>Factory Default</b>	<p><b>1,000</b> STEPS/REV (1/5)</p>	<p><b>10,000</b> STEPS/REV (1/50)</p>



## Idle Current Reduction

Your drive is equipped with a feature that automatically reduces the motor current by 50% anytime the motor is not moving. This reduces drive heating by about 50% and lowers motor heating by 75%. This feature can be disabled if desired so that full current is maintained at all times. This is useful when a high holding torque is required. To minimize motor and drive heating we highly recommend that you enable the idle current reduction feature unless your application strictly forbids it.

Idle current reduction is enabled by sliding switch #4 toward the **50% IDLE** label, as shown in the sketch below. Sliding the switch away from the **50% IDLE** label disables the reduction feature.



**Idle Current Reduction  
Selected  
(Factory Default)**



**No Current Reduction**

## Self Test

The *SureStep* drive includes a self test feature. This is used for trouble shooting. If you are unsure about the motor or signal connections to the drive, or if the *SureStep* drive isn't responding to your step pulses, you can turn on the self test.

To activate the self test, slide switch #1 toward the **TEST** label. The drive will slowly rotate the motor, 1/2 revolution forward, then 1/2 rev backward. The pattern repeats until you slide the switch away from the **TEST** label. The *SureStep* drive always uses half step mode during the self test, no matter how you set switches 2 and 3. The self test ignores the **STEP** and **DIRECTION** inputs while operating. The **ENABLE** input continues to function normally.



**Self Test ON**

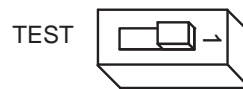

**Self Test OFF  
(Factory Default)**

## Choosing a Power Supply

### Voltage

Chopper drives work by switching the voltage to the motor terminals on and off while monitoring current to achieve a precise level of phase current. To do this efficiently and silently, you'll want to have a power supply with a voltage rating at least five times that of the motor. Depending on how fast you want to run the motor, you may need even more voltage. More is better, the only upper limit being the maximum voltage rating of the drive itself: 42 volts (including ripple).

If you choose an unregulated power supply, do not exceed 30 volts DC. This is because unregulated supplies are rated at full load current. At lesser loads, like when the motor is not moving, the actual voltage can be up to 1.4 times the voltage list on the power supply label. The STP-PWR-3204 power supply is designed to provide maximum voltage, approximately 32 VDC, while under load without exceeding the upper limit of 42 VDC when unloaded.

### Current

The maximum supply current you will need is the sum of the two phase currents. However, you will generally need a lot less than that, depending on the motor type, voltage, speed and load conditions. That's because the SureStep drive uses switching amplifiers, converting a high voltage and low current into lower voltage and higher current. The more the power supply voltage exceeds the motor voltage, the less current you'll need from the power supply.

We recommend the following selection procedure:

1. If you plan to use only a few drives, get a power supply with at least twice the rated phase current of the motor.
2. If you are designing for mass production and must minimize cost, get one power supply with more than twice the rated current of the motor. Install the motor in the application and monitor the current coming out of the power supply and into the drive at various motor loads. This will tell you how much current you really need so you can design in a lower cost power supply.

If you plan to use a regulated power supply you may encounter a problem with current foldback. When you first power up your drive, the full current of both motor phases will be drawn for a few milliseconds while the stator field is being established. After that the amplifiers start chopping and much less current is drawn from the power supply. If your power supply thinks this initial surge is a short circuit it may "foldback" to a lower voltage. With many foldback schemes the voltage returns to normal only after the first motor step and is fine thereafter. In that sense, unregulated power supplies are better. They are also less expensive.



---

*The SureStep™ STP-PWR-3204 power supply from AutomationDirect is the best choice of DC power supply to use with the SureStep™ STP-DRV-4035 microstepping drive.*

---

## Mounting the Drive

You can mount your drive on the wide or the narrow side of the chassis. If you mount the drive on the wide side, use #4 screws through the four corner holes. For narrow side mounting applications, you can use #4 screws in the two side holes.

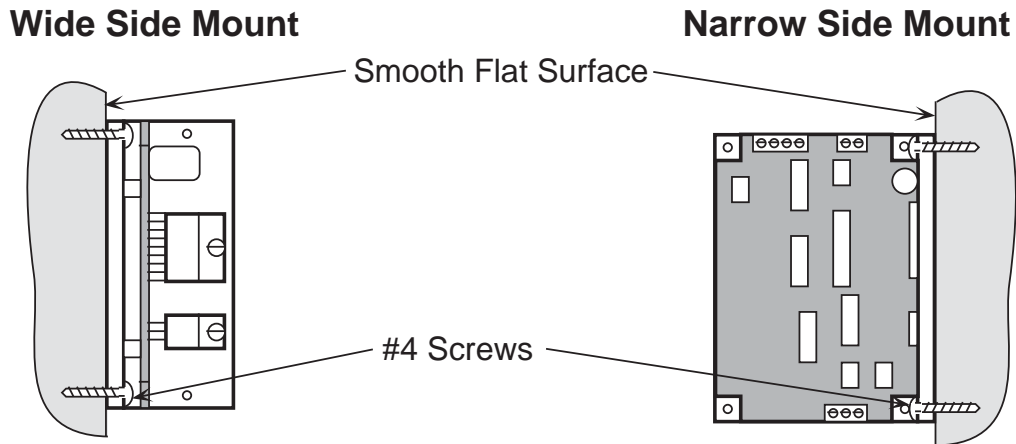

Unless you are running at 1 Amp/phase motor current or below, you may need a heat sink. Often, the metal subpanel being used for the control system will make an effective heat sink.

The amplifiers in the drive generate heat. Unless you are running at 1 amp or below, you may need a heat sink. To operate the drive continuously at maximum power you must properly mount it on a heat sinking surface with a thermal constant of no more than 4°C/Watt. Often, the metal enclosure of your system will make an effective heat sink.

Never use your drive in a space where there is no air flow or where other devices cause the surrounding air to be more than 70 °C. Never put the drive where it can get wet or where metal particles can get on it.

## Dimensions

